

# Kee Rigid Anchor - Epoxy Adhesive

## Technical Data Sheet KRA-EPX

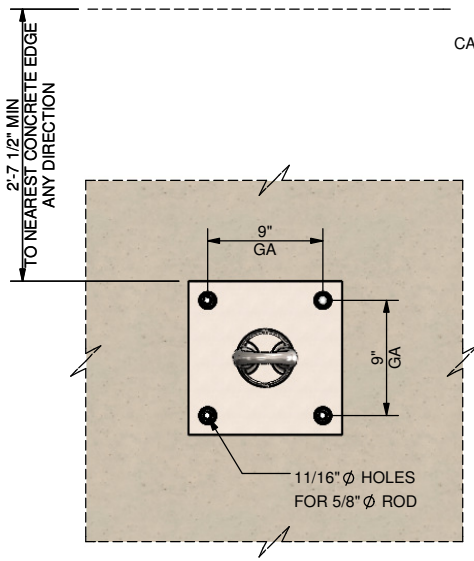

### ATTACHMENT POINTS



PLAN VIEW

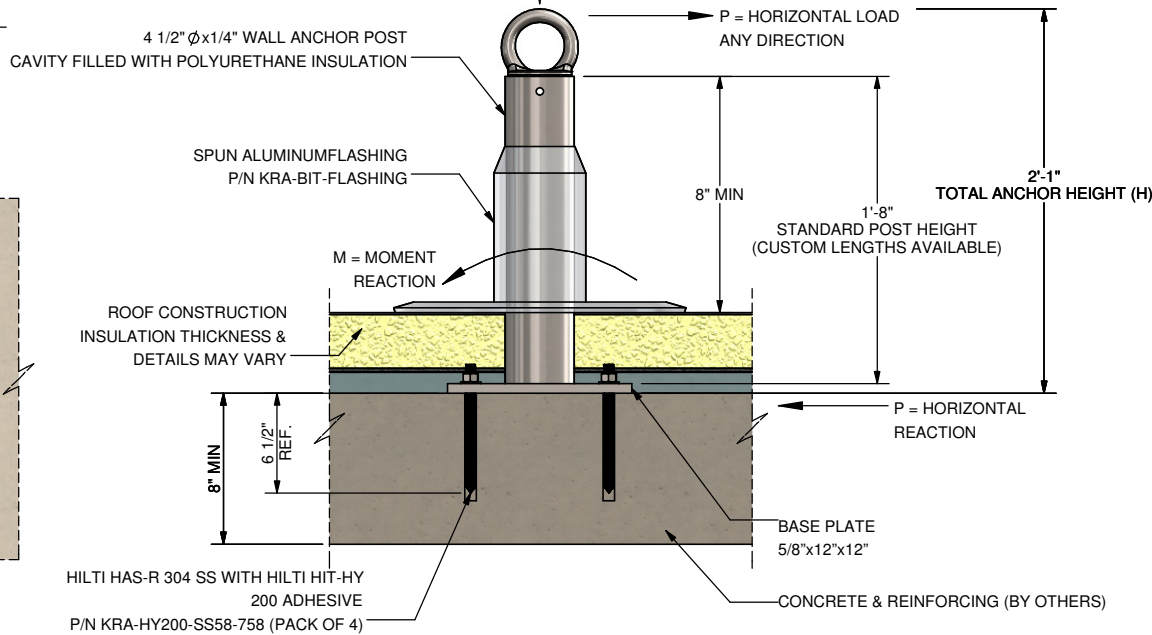

ELEVATION VIEW

### SYSTEM SPECIFICATION

#### General Notes

1. Unless noted otherwise, all dimensions are in feet and inches.
2. Each installation shall be approved by a qualified engineer to local standards and regulations.
3. Reinforcing of the underlying structure to be completed by others as required.

#### Installation

1. Layout to be performed by the customer.
2. Install in accordance with the manufacturer's instructions.
3. All components shall be fastened to the building structure using the indicated fastening method.
4. After installation, all anchors must be tested in accordance with manufacturer's instructions.

#### References

1. ANSI/AISC 360-16 "Specification for Structural Steel Buildings"
2. AISC Manual of Steel Construction (14th Edition)
3. AISC Design Guide 1, 2nd Edition - Base Plate and Anchor Rod Design
4. ANSI Z359.6 "Design of Active Fall Protection"
5. OSHA 1910.140 (d)
6. IBC 2018
7. ASCE 7-16
8. IWCA I-14.1-2001 "Window Cleaning Safety"

#### Design Loads

\*All loads are factored

H (inches)	P (lbs)	M (in-lbs)
25	5000	125000

#### Materials

1. All fabrication shall be performed in compliance with the AWS Code by AWS Certified Welders.
2. Steel material shall conform to the following unless noted otherwise:
  - 2.1. Hollow Structural Sections: ASTM A500 grade C, min yield strength 46ksi.
  - 2.2. Plates: ASTM A572 Grade 50, min yield strength 50ksi
  - 2.3. Top attachment point:
    - Forged D-ring: ASTM A105
    - Stainless steel u-bar: ASTM A276 Type 304 Condition A Cold Finished, min yield strength 70 ksi
  - 2.4. Base connection to existing structure:
    - Anchor rods: HILTI HAS-R 304 SS
    - Adhesive: HILTI HIT-HY 200-AOR-R, SPEC'D BY BLDG. ENGINEER
    - Concrete: Normal weight concrete, min compressive strength 3000psi
  - 2.5. Weld electrodes: (E70XX) for steel, (309L) for stainless
3. Structural steel connections:
  - 3.1. Field bolts installation shall be inspected in accordance with AISC manual.
  - 3.2. All welding shall conform to the revisions of the American welding society code.
  - 3.3. AWS D1.1 electrodes shall match base metals as specified in AISC manual.
  - 3.4. All bolts shall be installed with steel washer.
  - 3.5. All bolts shall be installed in properly aligned holes to a snug-tight condition.
  - 3.6. All welds shown on the drawings should be shop weld.
  - 3.7. Welded connection shall have a minimum of 1/4" fillet weld joint.
  - 3.8. Weld size shown on the design drawings are considered effective weld size and shall be increase in accordance with AWS as required by gaps or skews between components.

#### Paint and Coatings

1. All anchor components (excluding fasteners) shall be hot dipped galvanized in accordance with ASTM A123.

For information only. Not for construction unless provided as part of a complete design package.